



Forni elettrici modulari per pasticceria, panetteria e pizzeria ad alte prestazioni.

High performance modular electric ovens for pastry, bread and pizza.

PASTFOOD - PFA/PFD

CARATTERISTICHE TECNICHE

- 1 - 2 - 3 camere di cottura (A17 o A27) in acciaio alluminato con piano di cottura in lamiera bugnata o in refrattario (optional).
- Piano di cottura e cielo con resistenze corazzate in acciaio inox
- Pannello di controllo elettromeccanico o digitale
- Controllo separato delle temperature del piano di cottura e del cielo
- Isolamento termico
- Massima temperatura di cottura 450 °C
- Valvola regolabile per scarico vapori
- Sportello con finestra in vetro temperato
- Sportelli frontali controbilanciati
- Lampade alogene ad alta resistenza e capacità luminosa
- Disponibile in acciaio inossidabile

ACCESSORI

- Cella di lievitazione ermetica
- Supporto del forno
- Modulo cappa

OPTIONAL

- Piano refrattario
- 4 ruote (h = 16 cm + 2 cm per la cella di lievitazione)
- Piedi per celle di lievitazione (h min = 8 cm / max = 20 cm)
- Vaporiera (assorbimento massimo 1,4 Kw)
- Kit abbattimento vapori e odori con filtro ai carboni attivi (assorbimento massimo 0,7 Kw)

TECHNICAL SPECIFICATIONS

- 1 - 2 - 3 cooking chambers (H17 or H27) in aluminium coated steel with embossed steel or refractory (optional) floor
- Top and bottom stainless steel armored heating elements
- Electromechanical or digital control panel
- Top and bottom separate temperature control
- Thermal insulation
- Max cook temp 450 °C
- Adjustable steam exhaust valve
- Single tempered glazed door
- Counter balanced door
- High resistance and efficiency halogen lamps
- Available stainless steel

ACCESSORIES

- Hermetic prover compartment
- Oven support
- Hood module

OPTIONALS

- Refractory cooking floor
- 4 wheels (h = 16 cm + 2 cm for the prover)
- Feet for provers (h min = 8 cm / max = 20 cm)
- Steam injection system (max. absorption 1,4 Kw)
- Steam and odours damper kit for hood with active carbon filter (max. absorption 0,7 Kw)

1 CAMERA PFA + SUPPORTO ALTO
1 DECK PFA + HIGH STAND

ALLACCIO ELETTRICO
 ELECTRIC CONNECTION

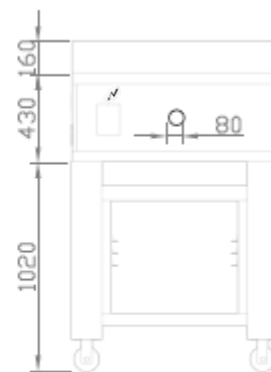
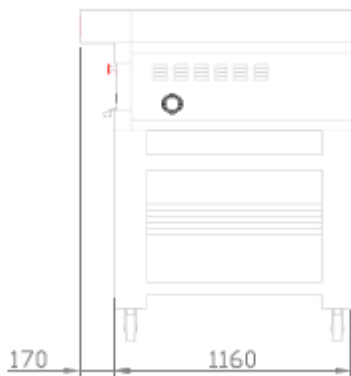
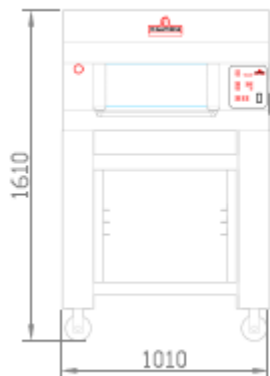

1 CAMERA PFA + CELLA DI LIEVITAZIONE ALTA
1 DECK PFA + HIGH PROVER

ALLACCIO ELETTRICO
 ELECTRIC CONNECTION

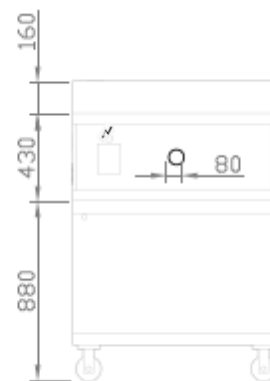
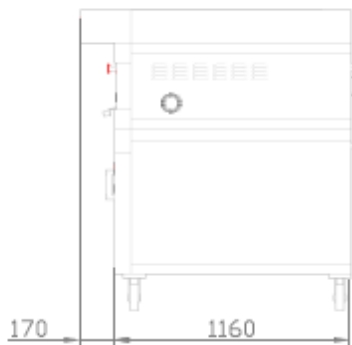
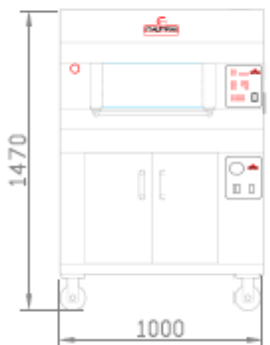

1 CAMERA PFD + SUPPORTO ALTO
1 DECK PFD + HIGH STAND

ALLACCIO ELETTRICO
 ELECTRIC CONNECTION

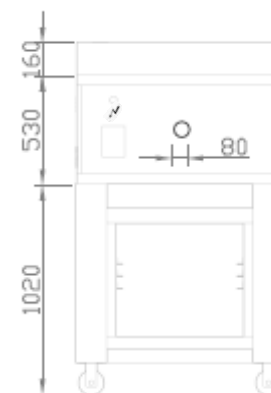
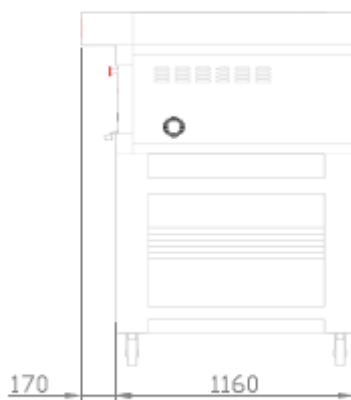

Italforni Pesaro s.r.l.

Loc. Chiusa di Ginestreto • Via dell'Industria 130 • 61121 Pesaro (PU) • Italia
 Tel +39 0721 48 15 15 - Fax +39 0721 48 24 53 info@italforni.it • www.italforni.it



1 CAMERA PFD + CELLA DI LIEVITAZIONE ALTA
1 DECK PFD + HIGH PROVER

ALLACCIO ELETTRICO
 ELECTRIC CONNECTION

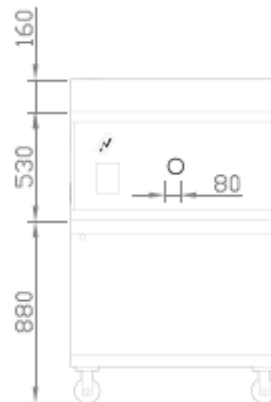

2 CAMERE PFA + SUPPORTO MEDIO
2 DECKS PFA + MID STAND

ALLACCIO ELETTRICO
 ELECTRIC CONNECTION

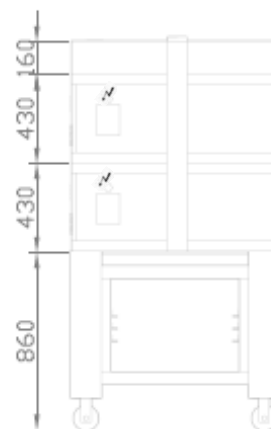
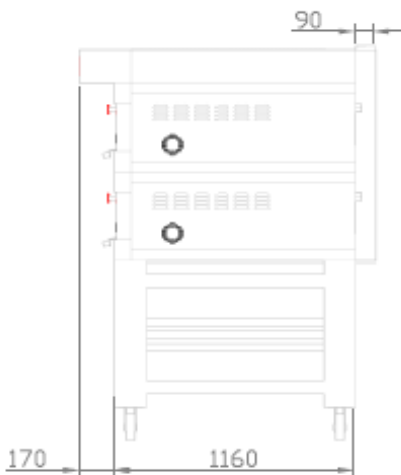
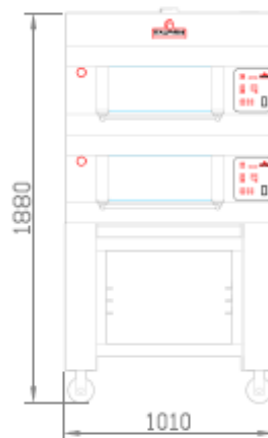

2 CAMERE PFA + CELLA DI LIEVITAZIONE ALTA
2 DECKS PFA + HIGH PROVER

ALLACCIO ELETTRICO
 ELECTRIC CONNECTION

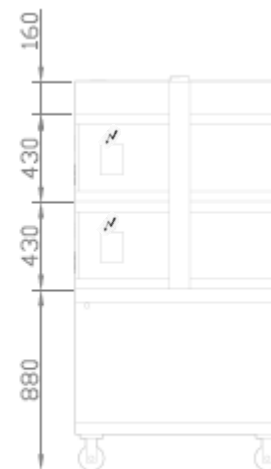
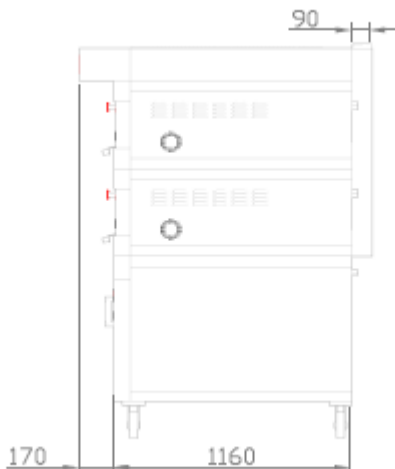
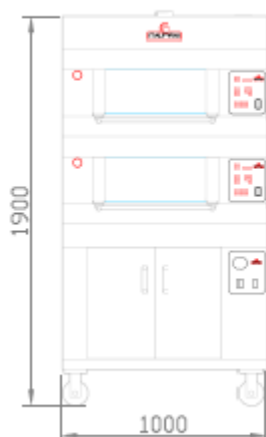

Italforni Pesaro s.r.l.

Loc. Chiusa di Ginestreto • Via dell'Industria 130 • 61121 Pesaro (PU) • Italia
 Tel +39 0721 48 15 15 - Fax +39 0721 48 24 53 info@italforni.it • www.italforni.it



2 CAMERE PFD + STAND MEDIO
2 DECKS PFD + MID STAND



ALLACCIO ELETTRICO
 ELECTRIC CONNECTION

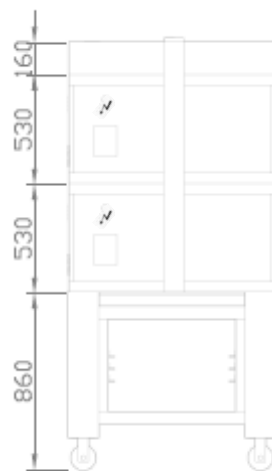

2 CAMERE PFD + CELLA LIEVITAZIONE ALTA
2 DECKS PFD + HIGH PROVER



ALLACCIO ELETTRICO
 ELECTRIC CONNECTION

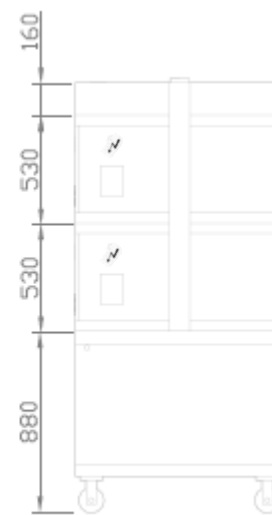

2 CAMERE 1 PFA + 1 PFD + SUPPORTO MEDIO
2 DECKS 1 PFA + 1 PFD + MID STAND



ALLACCIO ELETTRICO
 ELECTRIC CONNECTION

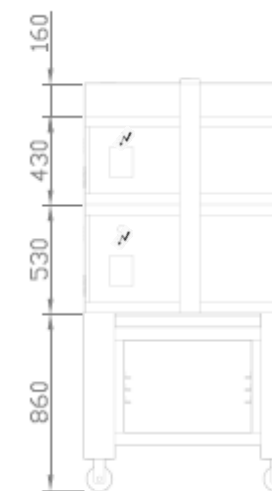

Italforni Pesaro s.r.l.

Loc. Chiusa di Ginestreto • Via dell'Industria 130 • 61121 Pesaro (PU) • Italia
 Tel +39 0721 48 15 15 - Fax +39 0721 48 24 53 info@italforni.it • www.italforni.it



2 CAMERE 1 PFA + 1 PFD + CELLA DI LIEVITAZIONE ALTA
2 DECKS 1 PFA + 1 PFD + HIGH PROVER

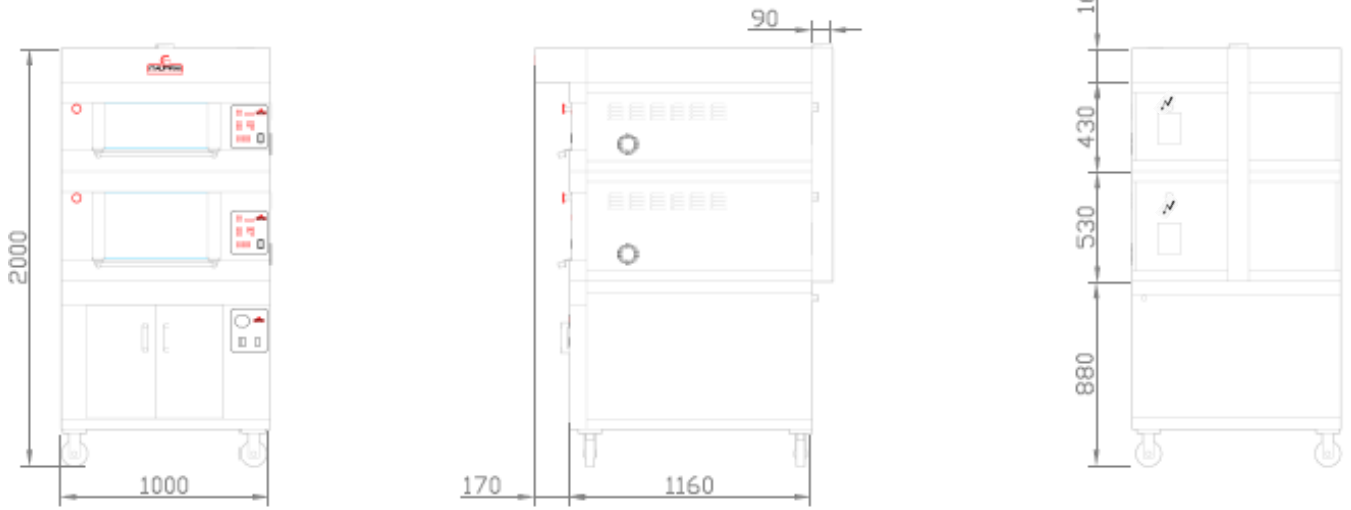

3 CAMERE PFA + SUPPORTO BASSO
3 DECKS PFA + LOW STAND

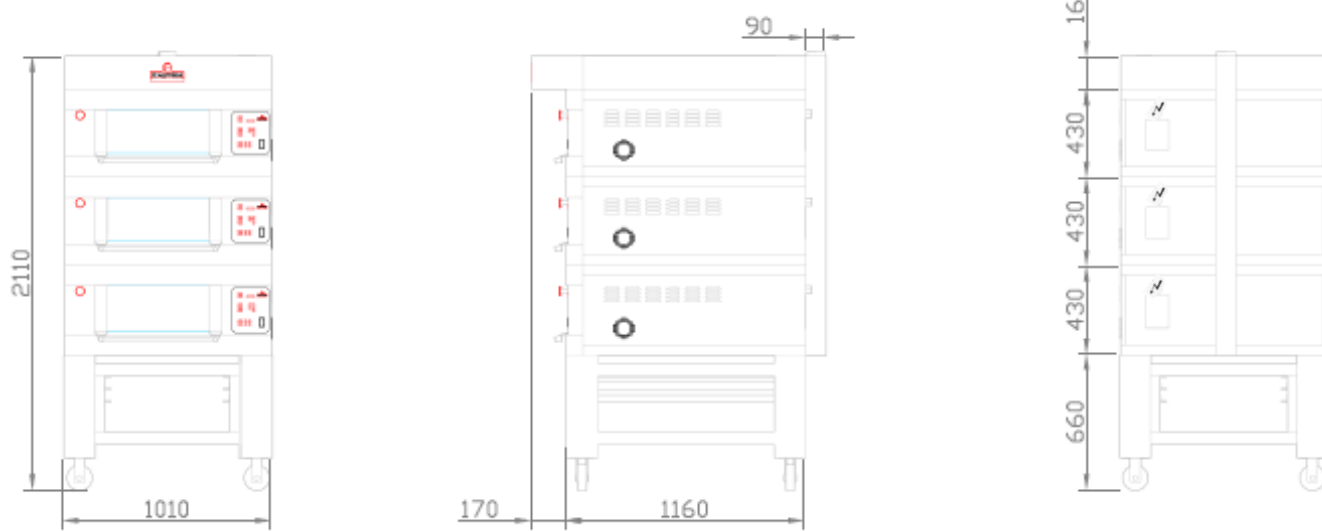

3 CAMERE PFA + CELLA DI LIEVITAZIONE BASSA
3 DECKS PFA + LOW PROVER

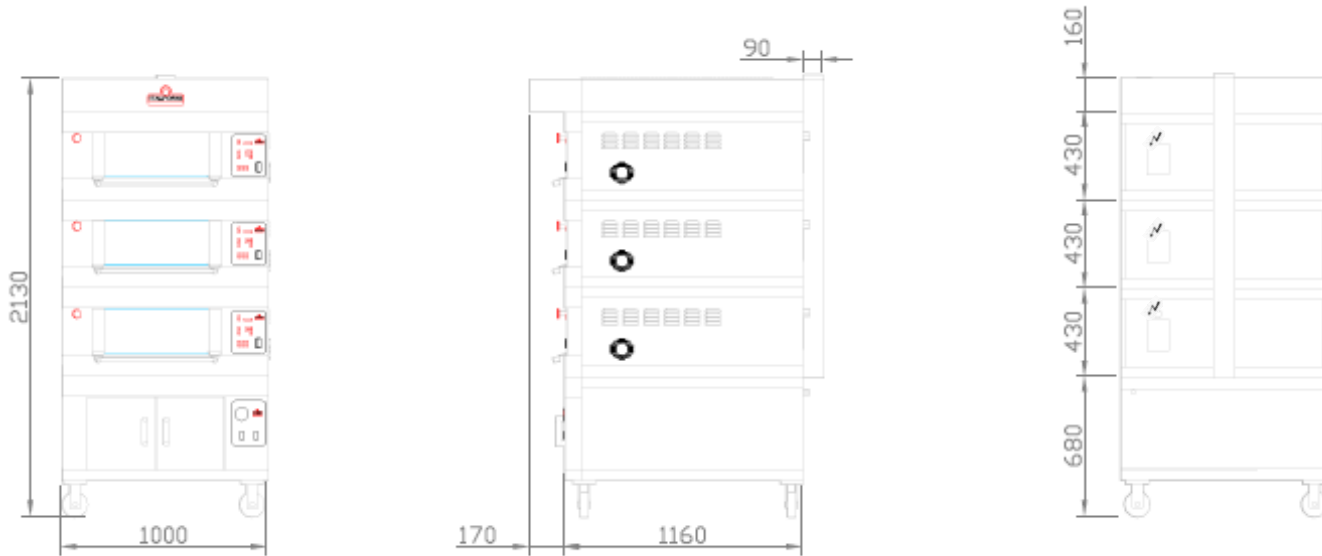

Italforni Pesaro s.r.l.

Loc. Chiusa di Ginestreto • Via dell'Industria 130 • 61121 Pesaro (PU) • Italia

Tel +39 0721 48 15 15 - Fax +39 0721 48 24 53 info@italforni.it • www.italforni.it



3 CAMERE 2 PFA + 1 PFD + STAND BASSO
3 DECKS 2 PFA + 1 PFD + LOW STAND

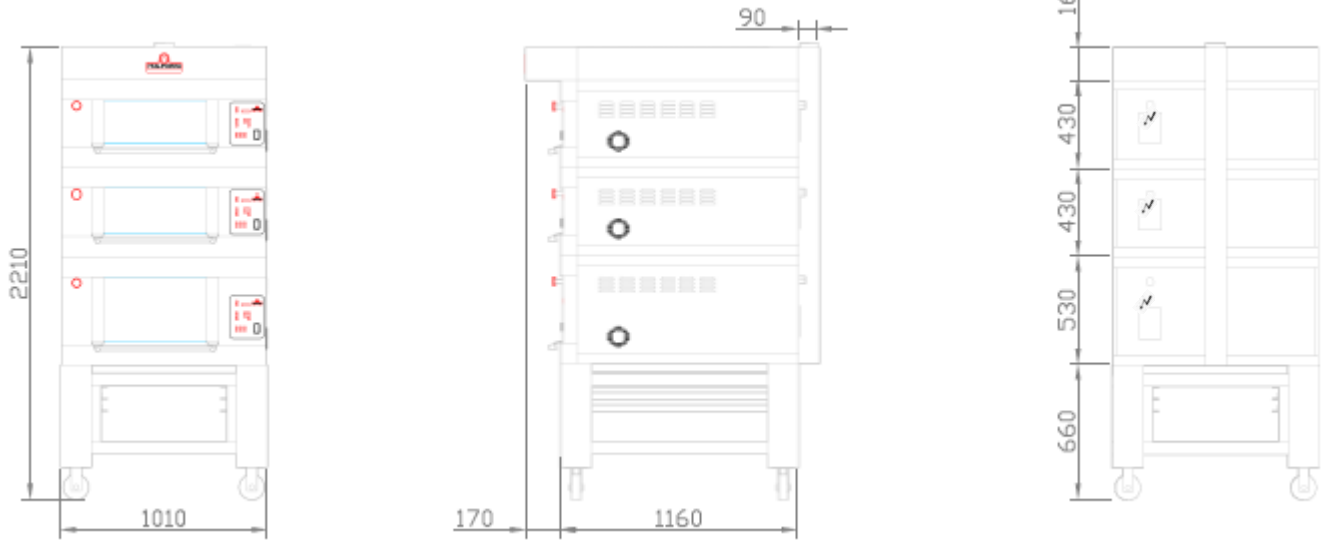

3 CAMERE 2 PFA + 1 PFD + CELLA LIEVITAZIONE BASSA
3 DECKS 2 PFA + 1 PFD + LOW PROVER

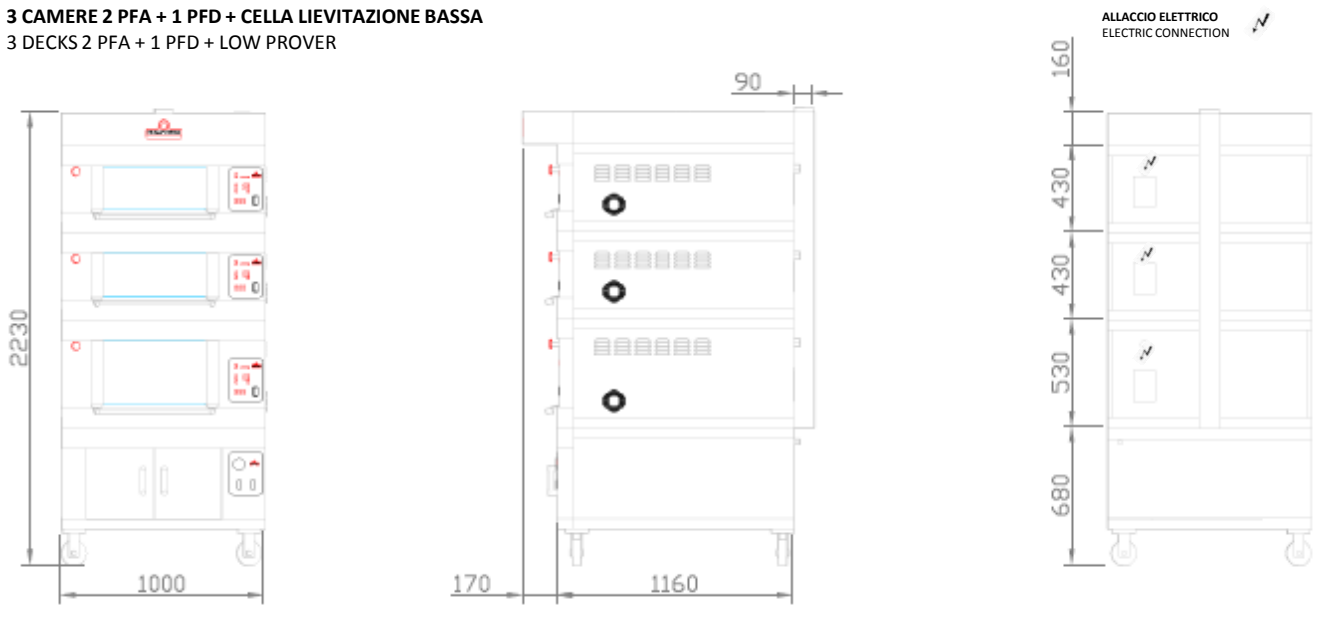

Italforni Pesaro s.r.l.

Loc. Chiusa di Ginestreto • Via dell'Industria 130 • 61121 Pesaro (PU) • Italia
 Tel +39 0721 48 15 15 - Fax +39 0721 48 24 53 info@italforni.it • www.italforni.it



VALVOLA REGOLABILE PER SCARICO VAPORI
ADJUSTABLE STEAM EXHAUST VALVE

Vista dall'alto 1 camera
 Top view 1 deck

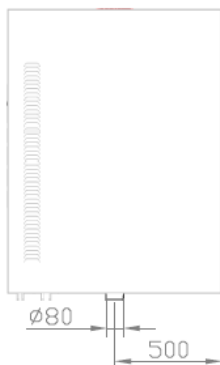

Vista dall'alto 2 o 3 camere
 Top view 2 or 3 decks



VAPORIERA
STEAM INJECTION SYSTEM

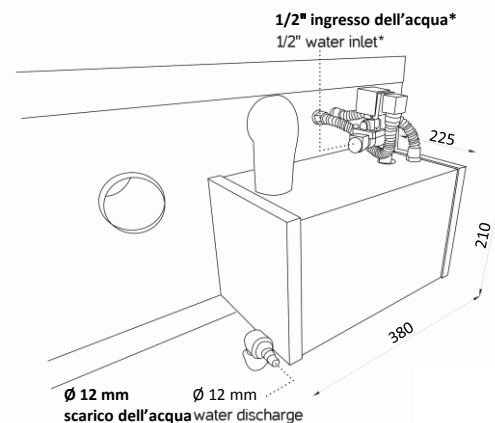

*Deve essere installato un riduttore di pressione massima di 0.5/0.6 mbar
 *0.5/0.6 mbar max pressure reduce has to be installed
Assorbimento massimo 1,4 Kw
 Max. absorption 1,4 Kw

CAPACITÀ DI CARICO PER CAMERA
LOADING CAPACITY PER DECK



Dimensioni interne
Internal dimensions
 A/H 17 x L/W 60 x P/D 80 cm
 2 Teglie 60x40 cm
 2 Baking pans 60x40 cm



Dimensioni interne
Internal dimensions
 A/H 27 x L/W 60 x P/D 80 cm
 2 Teglie 60x40 cm
 2 Baking pans 60x40 cm

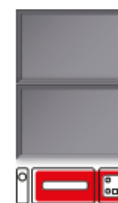

DATI TECNICI
TECHNICAL CHART



PastFood	Dimensioni interne (cm)			Dimensioni esterne (cm)			Peso	Alimentazione	Potenza	Potenza	Assorbimento	Temperatura	N° Teglie
	Internal dimensions (cm)			External dimensions (cm)			Weight	Supply	Power	Power	Absorption	Temperature	# Baking pans
	A/H	L/W	P/D	A/H	L/W	P/D	KG	V/Ph/Hz	KW	KW/h	Ampere	°C	60x40 cm
PFA - DECK	17	60	80	43	100	116	140	400/3/50-60	7,2	3,5	11	0/450	
PFD - DECK	27	60	80	53	100	116	170	400/3/50-60	7,2	3,5	11	0/450	
KPA/KPD - HOOD				16	100	133	28						
BPFA/BPFD - PROVER				70/50	100	116	75/60	230/1/50-60	1	0,5		0/90	14/8
SP 60/80 - STAND				86/70/50	101	116	46/42/36						18/12/6

Italforni Pesaro s.r.l.

Loc. Chiusa di Ginestreto • Via dell'Industria 130 • 61121 Pesaro (PU) • Italia
 Tel +39 0721 48 15 15 - Fax +39 0721 48 24 53 info@italforni.it • www.italforni.it

